



SIGNALINE

Signaline Auto Cable Collector, Page 1



Signaline Heat sensing cable is frequently installed around the rim of a floating tank. Maintaining an electrical connection between the heat sensing cable on the tank roof and the top of the tank can be a problem due to the rise and fall of the floating roof.

When the tank is full, the cable is stowed within the Signaline Auto Collector. The Auto Collector automatically unreels the connecting cable as the roof level falls and reels the cable into the collector as the roof rises. It is a mechanical device and does not require a power supply.

The cable is held at an optimised tension to prevent it flapping in high winds.

The mechanism is enclosed within a stainless steel (AISI 304) cabinet. The connecting cable has good resistance to chemical agents and high temperatures.

The unit can be installed both in a vertical or horizontal position by means of fixing holes located on both sides. A removable rain shield has a rubber seal surrounding the cable inlet to obtain a protection degree of IP42. Ingress of water will not harm the mechanism, the cable is terminated within an IP65 junction box mounted on the side of the auto collector

A removable plate allows for the inspection of the spring mechanism and maintenance without the need to remove the unit.

Specification:

Dimensions	400 x 400 x 150 mm (H x W X D)
Weight	25kgs
Box	Stainless Steel AISI 304
Internal Spring	Carbon Steel
Internal Parts	ABS/Fibreglass
Type Of Cable	4 Conductors 1mm ²
Cable external coating	Santoprene, resistant to chemical agents. Flame retardant
Operating Temperature	-40 - +70°C
Resistance	19.5 Ω/Km
Capaictance	80nF/Km
Inductance	0.9mH / Km
Insulation Resistance	100 MΩ/Km
Operating Voltage	300/500V
Junction Box Material	Glass reinforced polyester, complete with terminal board and cable glands (blue coloured for intrinsically safe circuits).
Operating Temperature of Junction box	-20 to +70°C

LGM PRODUCTS LTD
UNIT 18 RIVERSIDE INDUSTRIAL ESTATE
FARNHAM
SURREY GU9 7UG
UNITED KINGDOM

TEL +44 (0) 1252 725257
FAX +44 (0) 1252 727627
E-mail sales@Lgmproducts.com
www.signaline.com



SIGNALINE

Signaline Auto Cable Collector, Page 2

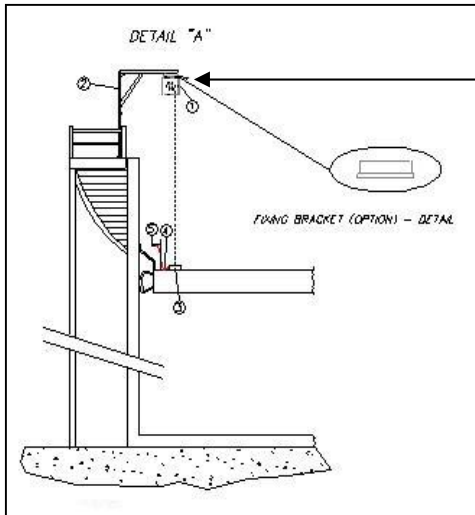

The Signaline auto Cable collector is fixed above the floating roof tank with the cable retracting from the bottom. This allows the cable to stretch and retract as the tank raises and lowers. Above shows the fixings of the cable reeler. Below is a diagram outlining the system.

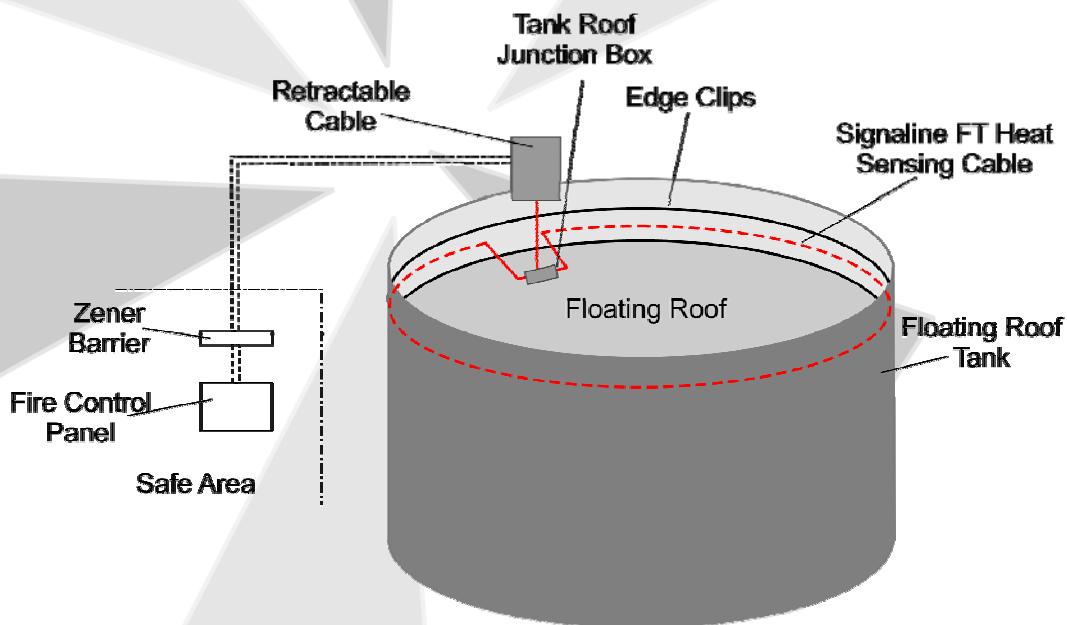

LGM PRODUCTS LTD
 UNIT 18 RIVERSIDE INDUSTRIAL ESTATE
 FARNHAM
 SURREY GU9 7UG
 UNITED KINGDOM

TEL +44 (0) 1252 725257
 FAX +44 (0) 1252 727627
 E-mail sales@lgmproducts.com
www.signaline.com