



FT-EOL

Signaline FT, FT-R and FT-X EOL Enclosure



Compatible with: Signaline FT, FT-R and FT-X
IP66 enclosure

Alarm and Fault Test Switches included
UV and chemical resistant

Fire
detection



Signaline





Model	Signaline FT-EOL
Dimensions	94 x 94 x 57mm
Pack weight	0.1kg
IP rating	IP66, Environmental group III
Operating temp.	-35°C to +55°C
Terminal blocks	EOL: 2x 5mm Rising Clamp Cable: 2x removable header 5mm Rising clamp
Cable glands	2x IP67 rated glands included
Mounting	Wall mounted 4x Ø4mm holes, 79mm apart
Material	Polycarbonate enclosure with non-ageing polyurethane seal
Colour	Grey (RAL 7035)



The Signaline FT-EOL End-of-Line Unit has been designed for use with the LocatorPlus Control Unit and FT, FT-R or FT-X ranges of Signaline Linear Heat Detection cables.

It is designed to effectively terminate up-to two zones of Signaline Linear Heat Detection cable in a secure, weatherproof enclosure.

Furthermore, the built in switches for testing a fault and alarm condition allow the integrity of the whole system to be functionally checked in situ, providing comprehensive testing and maintenance of the system.

Visit Signaline.com for our full range of heat detection solutions



Signaline cable is proudly manufactured in the UK

Wiring Diagram

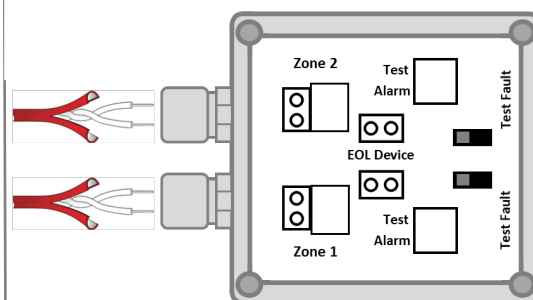

Conventional Systems

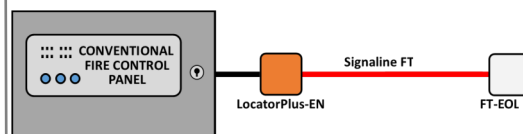

Addressable Systems

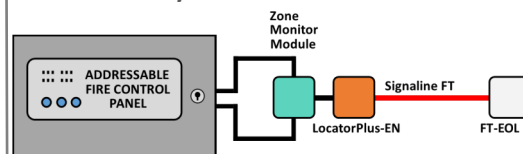

Hazardous Areas

