



Signaline HD+ Junction Box

Junction Box for Signaline HD+
Programmable Temperature Linear Heat Detector



Resettable Line Type Heat Detector

EN54 Part 22 Approved

UL Approved

Controller to set alarm and pre-alarm thresholds

Fire
detection



Signaline





Signaline HD+ JB is to connect Signaline HD+, Signaline HD+ R or Signaline HD+ S, or connect detection cable and leader cable Signaline HD+ EOL



Model	Signaline HD+ JB
Alarm class	EN54-22:2015+A1:2020 (Class A1I, A2I and BI)
Operating temperature	-20°C to +50°C
Connections	5 Din Rail Mounting Terminal Block
IP and impact rating	IP65 (IK08)
Weight	121g
Cable Entries	7 x M20/M16 (2 x cable glands included)
Mounting	4 x M5

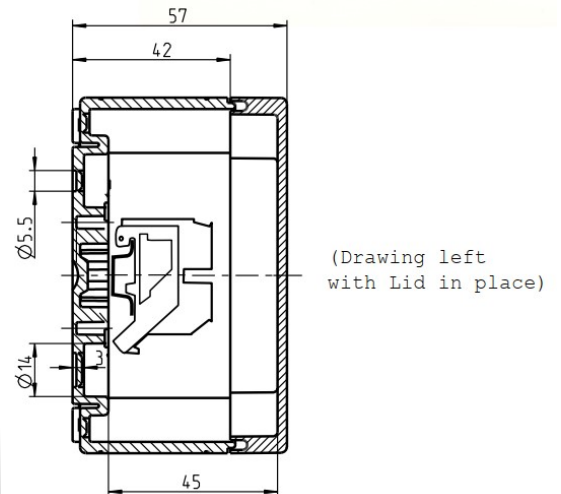
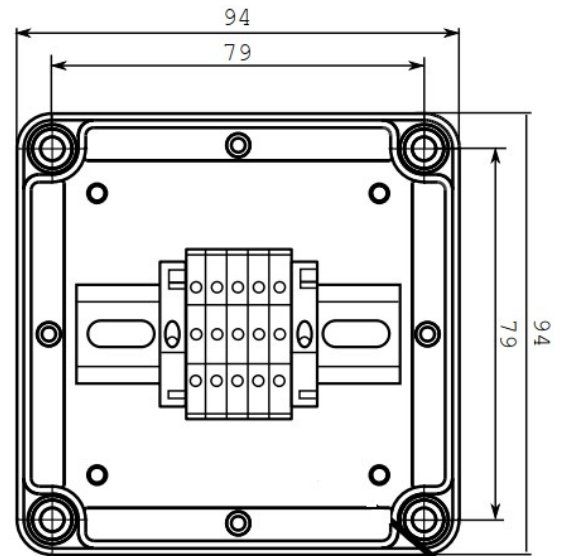

Signaline HD+ is an advanced Programmable Linear Heat Detector.

When used with the Signaline HD+ Controller and EOL, the user can select various alarm response temperature or class as well as pre-alarm settings.

The controller is easily adjusted for the length of cable being used.

Signaline HD+ Programmable Linear Heat Detectors are resettable after a over-heat event.

For our full range of linear heat detectors please visit www.Signaline.com



Signaline is proudly manufactured in the UK